

PS150-BOOST

provides city water pressure, anywhere. It has been a standard in home renewable energy systems since 1986. It is economical for domestic water supply, drip irrigation and water purification. Use solar-electric power to provide 250 to 10,000ltrs per day from shallow water sources. PS-BOOST can push water as high as 140m (460ft)

For 12 to 24V systems (1-2 solar modules or batteries in series) uses only one and the same motor and controller for solar direct or battery systems. Same flow at 12V or 24V ! PS-BOOST is not submersible, but can draw water from shallow wells, springs, cisterns, tanks, ponds, rivers and streams and push it through miles of pipeline. Slow pumping minimizes the size and cost of the solar array-battery system, wire and piping.

PS-BOOST is more powerful, quieter and much more durable than plastic RV/Marine pumps. It is less expensive than submersible DC pumps. Wearing parts typically last 5 to 10 years. Overall life expectancy is 15 to 20 years.

Construction & Features

- Rotary vane mechanism (positive displacement) made of forged brass, carbon-graphite and stainless steel
- Clamp on assembly avoids alignment problems
- Handles sea water, dissolved minerals
- Survives most freezes
- Brushless DC motor (maintenance free) is same for 12 and 24V application with SAME flow rates!
- MPP tracking, current booster for solar direct applications, Pump speed control , Low Voltage Disconnect for battery protection, Terminals for float / remote switch and low water probe.
- 12/24V-20A Battery charger included
- Installation and Service Manual is highly detailed and illustrated

Suction Capacity

- 5 vertical meter (20ft) at sea level. Subtract 1m for every 1000m altitude. Pump should be placed as low and as close as possible to the water source. Suction capacity may be further limited by intake pipe friction (or clogged filter) Intake piping should be 1" or larger.

Filtration Requirement

- This pump CANNOT tolerate dirt. Water MUST be filtered clear. If water is very dirty, improve the source or consider a different pump.

PV-Direct (non-battery) Requirements

- The rated power of the PV array must exceed pump watts by 20% or more. Voc max = 50Volt
- A linear current booster incl MPPT (maximum power point tracking) is already included !
- Solar Tracker (optional) will increase daily yield (40-55% in summer)

Installation

- Pump may be mounted horizontally or vertically.
- Pump must not be submerged
- It may be placed inside a 6" (120cm) or larger well casing, suspended by a rope



PS150-Boost with Installation Kit #2065 and Inline Filter #2075

Accessories

- Inline Filter: (10") Uses standard filter cartridges
- Installation Kit includes: Pressure switch, pressure gauge, check, drain and shut-off valves and tank tee.
- Float switch for tank shut off if full.
- Well probe sensor to protect pump from dry-running.

Dimensions

- Pump Unit Length: 33cm (13")
Weight: 7kg (15 lb)
- Controller 260 x 175 x 100 mm (10" x 7" x 4")
Weight: 1,5kg (3,6l b)

Warranty

1 year against defects in materials and workmanship

Larger values = BOOST 240 pump

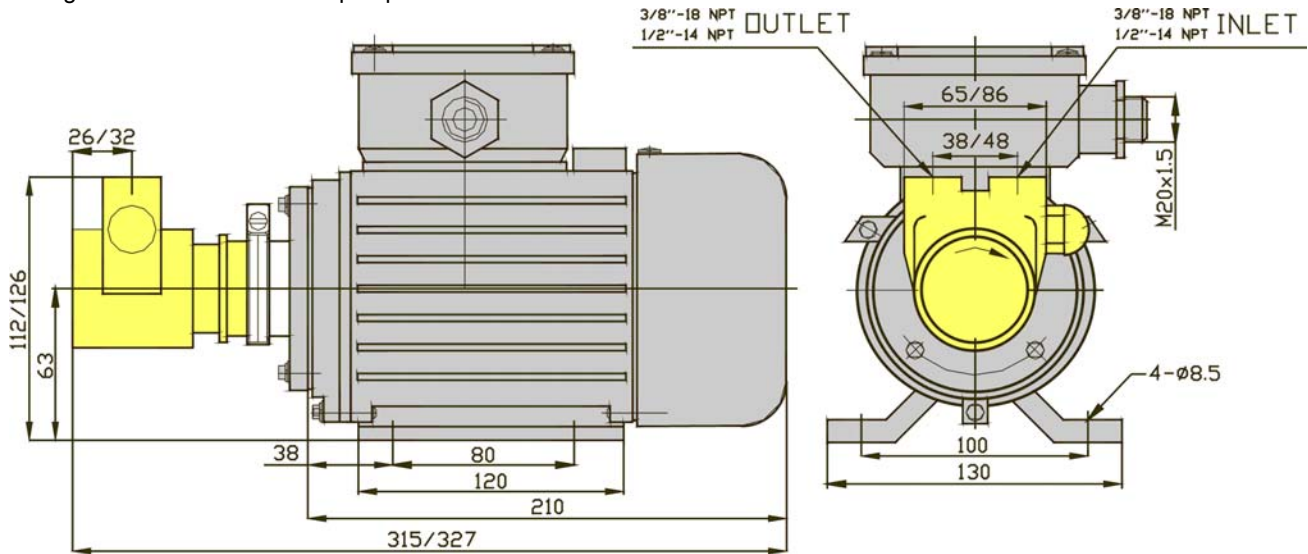

PS150 BOOST Performance Chart PV or Battery 12 or 24V										
Pump #										
Total Lift		PS150 BOOST 60			PS150-BOOST 125			PS150 BOOST 240		
Feet	Meters	L/h	US-G/h	Watts	L/h	US-G/h	Watts	L/h	US-G/h	Watts
17	5	260	69	35	475	125	50	900	238	65
33	10	257	68	40	470	124	55	895	236	90
50	15	254	67	45	470	124	62	890	235	105
65	20	252	67	55	469	124	70	880	232	120
83	25	250	66	63	460	122	80	875	231	135
100	30	248	66	72	450	119	90	870	230	150
132	40	246	65	80	448	118	105	865	229	200
150	45	244	64	85	447	118	112	860	227	225
165	50	242	64	90	446	118	120			
200	60	240	63	95	425	112	140			
231	70	239	63	110	419	111	160			
265	80	238	63	125	409	108	185			
300	90	236	62	140	407	108	200			
330	100	234	62	165						
400	120	228	60	185						
460	140	222	59	220						

Actual performance may vary 10% from specifications

Battery Sample Layout :

Lift / water req.: 20m lift and 1000L per day required

Solar radiation: 6kWh/m²/day say 6 peak sun hours

Pump: PS150 BOOST 60 pump, 1000L / 252L/h = 4h pumping time

Energy req.: 4h X 55Watt = 220Wh X 1,5 =330Wh (const. factor for battery systems to account for battery, charging and array losses)

Array size: 330Wh / 6 peak sun hour day (summer) = 55Wp array is needed

Battery size: 330Wh / 12V = 28Ah X 2 = **60Ah min. size** (min. factor for batteries)

Choose a larger array and battery size to compensate bad weather periods.

Solar Direct Sample Layout :

Lift / water req.: 40m and 2500 L per day

Solar radiation: 6kWh/m²/day say 6 peak sun hours

Selected Pump: 2500L / 6 = 416L/h -> PS150 BOOST 125

Selected Array : 105 Watt + 20% = 126 -> 130Wp array

Handy Hint:

Try to select the smallest pump. A smaller pump will start earlier in the morning (and pumps later in the afternoon) and it will pump more during low light conditions than a larger type.

